



**Polymer  
Solutions  
International, Inc.**

**Safe • Strong • Durable**

# ProStack® Pallets

## ProGenic-HD

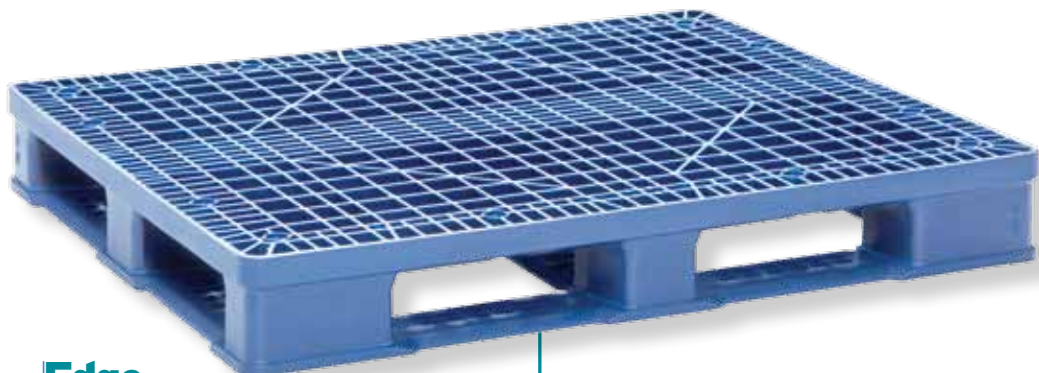

**Edge**  
Rackable

### Features

- Hygienic
- Flow Through Design
- Easy to inspect
- One Piece
- Fire Retardant- FM approved- Non-deca BDE
- Edge-Rackable up to 2,200 lbs.
- Anti-microbial additive options available
- 4-way entry for forklift and pallet jacks
- Ideal for Food, Pharmaceutical and Medical applications
- Available in 3 Stringer Model
- Decoration Options: Hotstamp or Molded-In Logo

Grommets Optional

Hygienic Flow Through Design

6-inch HD/  
5-inch LD models

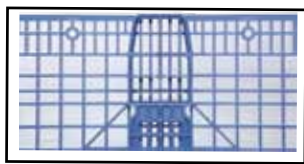

### SUPPORTING MEMBERS OF



**Polymer  
Solutions  
International, Inc.**

**Contact us for more information:**

TEL (610) 325-7500

P.O. Box 310

FAX (610) 356-6327

Newtown Square, PA 19703

**Call Us! Toll Free (877) 444-7225 (RACK)**

info@prostack.com | www.prostack.com | www.prostackpallets.com

# ProGenic-HD

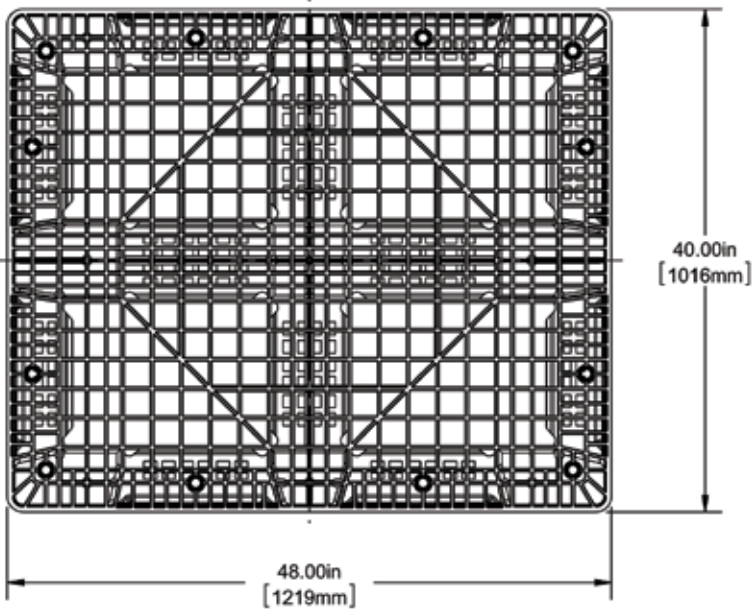

TOP VIEW

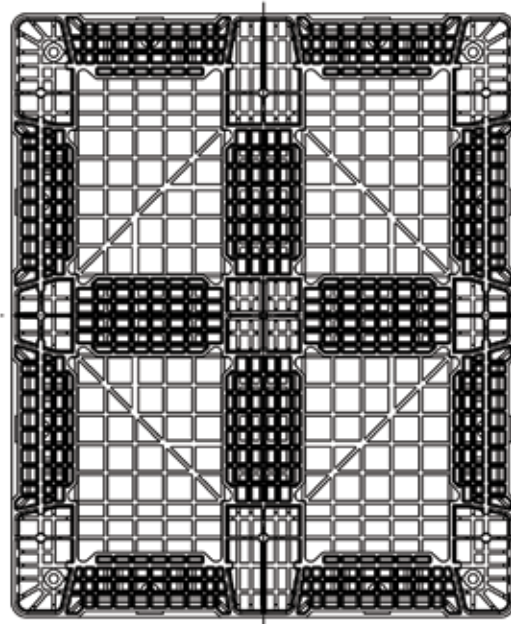

BOTTOM VIEW

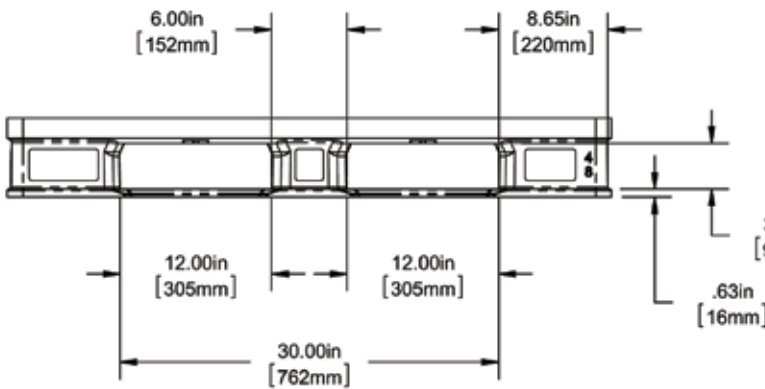

SIDE VIEW - 48"

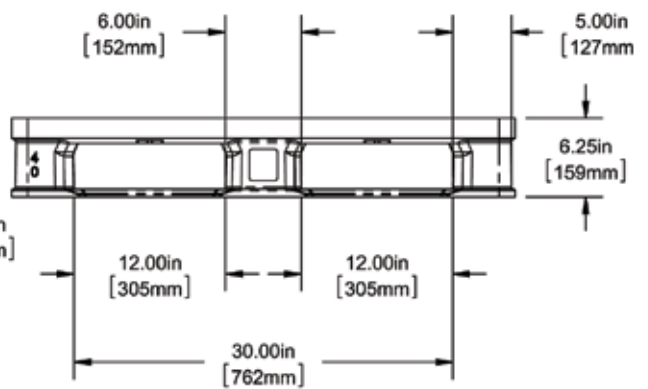

SIDE VIEW - 40"

## 40" x 48" Full Perimeter

Specifications	Dimensions				Load Rating (lbs.)				Truckload Capacity	Ocean Containers
	Width	Length	Height	Weight	Static	Dynamic	Selected Edge Racking*	Supported Racking		
Progenic-HD	40in.	48in.	6.25in.	45 lbs.	20,000	5,000	2,200	5,000	53'	40' HC

\*Unitized load at 72°F



**Polymer Solutions International, Inc.**

**Contact us for more information:**

TEL (610) 325-7500

P.O. Box 310

FAX (610) 356-6327

Newtown Square, PA 19703

**Call Us! Toll Free (877) 444-7225 (RACK)**

info@prostack.com | www.prostack.com | www.prostackpallets.com